

# **CURRENT MEASUREMENT SHUNT**

**CS-10/500**

**USER MANUAL**

**Copyright © 2017 MEGAIMPULSE Ltd. All Rights Reserved.**

MEGAIMPULSE LTD. PROVIDES THIS MANUAL "AS IS" WITHOUT WARRANTY OF ANY KIND, EITHER EXPRESS OR IMPLIED, INCLUDING BUT NOT LIMITED TO THE IMPLIED WARRANTIES OR CONDITIONS OF MERCHANTABILITY OR FITNESS FOR A PARTICULAR PURPOSE. IN NO EVENT SHALL MEGAIMPULSE LTD., ITS DIRECTORS, OFFICERS, EMPLOYEES OR AGENTS BE LIABLE FOR ANY INDIRECT, SPECIAL, INCIDENTAL, OR CONSEQUENTIAL DAMAGES (INCLUDING DAMAGES FOR LOSS OF PROFITS, LOSS OF BUSINESS, LOSS OF USE OR DATA, INTERRUPTION OF BUSINESS AND THE LIKE), EVEN IF MEGAIMPULSE LTD. HAS BEEN ADVISED OF THE POSSIBILITY OF SUCH DAMAGES ARISING FROM ANY DEFECT OR ERROR IN THIS MANUAL OR PRODUCT.

SPECIFICATIONS AND INFORMATION CONTAINED IN THIS MANUAL ARE FURNISHED FOR INFORMATION ONLY, AND ARE SUBJECT TO CHANGE AT ANY TIME WITHOUT NOTICE, AND SHOULD NOT BE CONSTRUED AS A COMMITMENT BY MEGAIMPULSE LTD. MEGAIMPULSE LTD. ASSUMES NO RESPONSIBILITY OR LIABILITY FOR ANY ERRORS OR INACCURACIES THAT MAY APPEAR IN THIS MANUAL, INCLUDING THE PRODUCTS AND SOFTWARE DESCRIBED IN IT.

Products and corporate names appearing in this manual may or may not be registered trademarks or copyrights of their respective companies, and are used only for identification or explanation and to the owners' benefit, without intent to infringe.

## **Megaimpulse Ltd. contact information**

Address:	26 Polytechnicheskaya str., St. Petersburg, 194021 Russia
www:	<a href="http://www.megaimpulse.com">http://www.megaimpulse.com</a>
e-mail:	<a href="mailto:mp@power.ioffe.rssi.ru">mp@power.ioffe.rssi.ru</a>
fax:	+7-812-297-3145

## CONTENTS

Package content .....	2
General view of CS-10/500 current measurement shunt .....	2
Safety manual .....	3
Technical specification .....	4
The drawing of CS-10/500 current measurement shunt .....	5
Putting the shunt into operation .....	6
Warranty .....	10

## PACKAGE CONTENT

Please check the package for the following items:

- ✓ CS-10/500 current measurement shunt (hereinafter "shunt")
- ✓ 20dB 18 GHz attenuator with SMA connectors
- ✓ coaxial cable assembly with SMA connectors
- ✓ SMA-to-BNC adapter

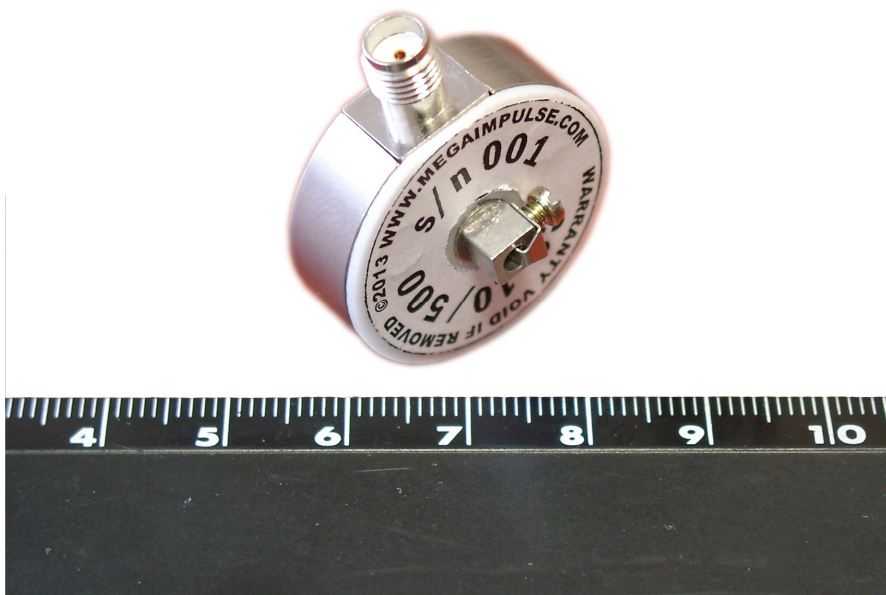

Fig. 1. General view of CS-10/500 current measurement shunt.

# SAFETY MANUAL

## Electrical safety

- CS-10/500 shunt is designed for short pulse current measurement in high voltage circuits. Please be very careful and operate by qualified personnel only.
- There is a risk of electric shock, strong electromagnetic interference, damage of electronic equipment in case of improper use.
- The registered by shunt signal is applied to the oscilloscope input. Please ground the oscilloscope obligatory. It is not recommended the connection of the shunt directly to the oscilloscope input without using of the attenuator. This attenuator may prevent the damage of the oscilloscope in case of improper operation.
- It is strongly prohibited to connect or disconnect the shunt to/from the system while HV power supplies or HV pulse generators are switched on.

## Operation safety

- Please read this manual before installing and using of the shunt.
- Before using the product, make sure that all cables are applicable and not damaged. All the connectors should be clean and dry, free from dust, dirt and any obstacles.
- The shunt is designed to work in normal laboratory conditions. Avoid dust, humidity and temperature extremes. Do not place the shunt in any place where it may become wet.
- If you encounter any technical problem with the shunt, please contact with Megaimpulse Ltd. Do not try to repair it by yourself.

**TECHNICAL SPECIFICATION OF CS-10/500  
CURRENT MEASUREMENT SHUNT**

Current/voltage transfer ratio: without 20dB attenuator with 20dB attenuator	10 A/V 100 A/V
Peak pulse current	500 A
Pulse polarity	any
Rise time (transient response)	1 ns
Internal impedance (in measured power circuit)	0.2 Ohm
Maximum dissipated power	2 W
Output connector	SMA
Size (for reference only)	27 x 38 x 18 mm <sup>3</sup>
Suitable wire diameter	0.8mm – 2mm, AWG20 – AWG12

- To prevent overheating and damage of the shunt please do not exceed the maximum dissipated power.  
The dissipated power can be estimated:

$$P = I_m^2 \times R_{sh} \times t \times f, \text{ where}$$

$I_m$  – peak pulse current,  
 $R_{sh}$  – internal shunt resistance 0.2 Ohm,  
 $t$  – pulse width,  
 $f$  – pulse repetition rate.

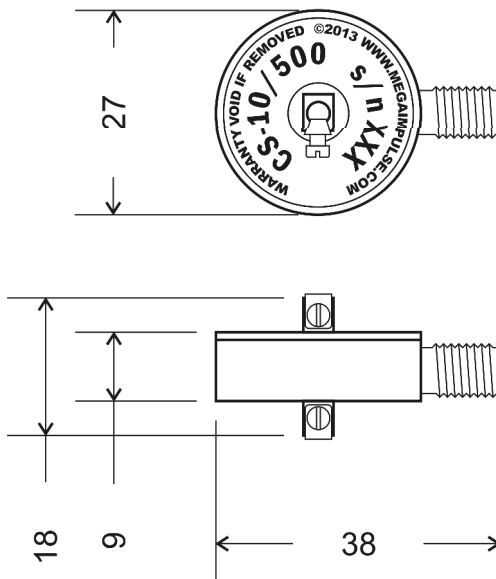

\* All the dimensions are in mm and are given for reference only;

Output connector to oscilloscope is SMA type;

Two power circuit screw terminals are suitable for the wires with diameter 0.8mm – 2mm (AWG20 – AWG12);

The shunt should be installed into the ground wire break between the load and HV coaxial cable ground contact, i.e. cable braid. HV contact of the shunt (top on the figure) should be connected to the load, ground shunt contact (bottom in the figure) should be connected to HV coaxial cable ground contact.

Fig. 2. The drawing of CS-10/500 current measurement shunt.

## PUTTING THE SHUNT INTO OPERATION

➔ Please follow strictly the next steps. It helps to prevent damage of the equipment and personnel injury.

### Step 1.

Unpack the shunt and check the presence into the package of the following items:

- CS-10/500 current measurement shunt;
- 20dB 18 GHz attenuator with SMA connectors;
- coaxial cable assembly with SMA connectors;
- SMA-to-BNC adapter.

### Step 2.

Ground the oscilloscope and other testing equipment if required.

### Step 3.

Connect the shunt serially with the load. It is very important to install the shunt in proper place and in proper orientation. Otherwise it may results in the damage of the connected equipment. The shunt should be installed in the break of the load ground wire, i.e. between HV coaxial cable ground wire (cable braid) and load ground contact (please see Fig.3).

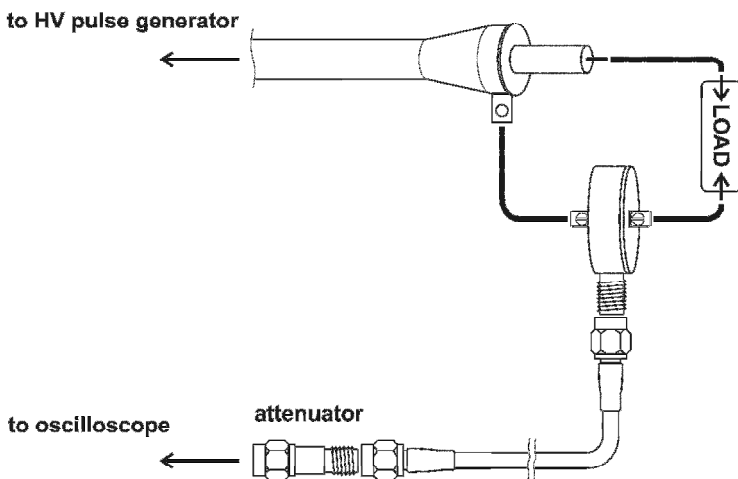

Fig. 3. Set up of CS-10/500 current measurement shunt serially with the load.



The shunt has two screw terminals for connection to the power circuit: ground contact which is connected with the metal body of the shunt, and isolated HV contact. Please attach shunt ground contact to the ground of HV coaxial cable and attach HV shunt contact to the load ground contact correspondingly; the same as is shown in Fig.3.

- It is recommended to keep the total length of the wires between HV coaxial cable, the load and the shunt below 10 cm.

Attach the signal coaxial cable assembly directly to SMA connector of the shunt, and connect the other cable assembly end to the oscilloscope through 20dB attenuator and SMA-to-BNC adapter. The oscilloscope should have 500 MHz or more bandwidth for correct measurement.

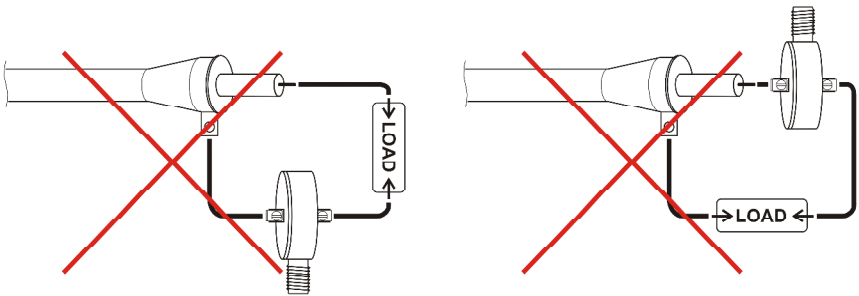

Fig. 4. Improper connection of the shunt which may results in damage of the equipment.

#### Step 4.

Set the following oscilloscope operation regime (see Fig. 5):

- Input impedance of the oscilloscope channel – 50 Ohm;
- External attenuation – 100:1 (100x);
- Coupling – DC;
- Bandwidth – full;
- Scale 50 V/div or 100 V/div.

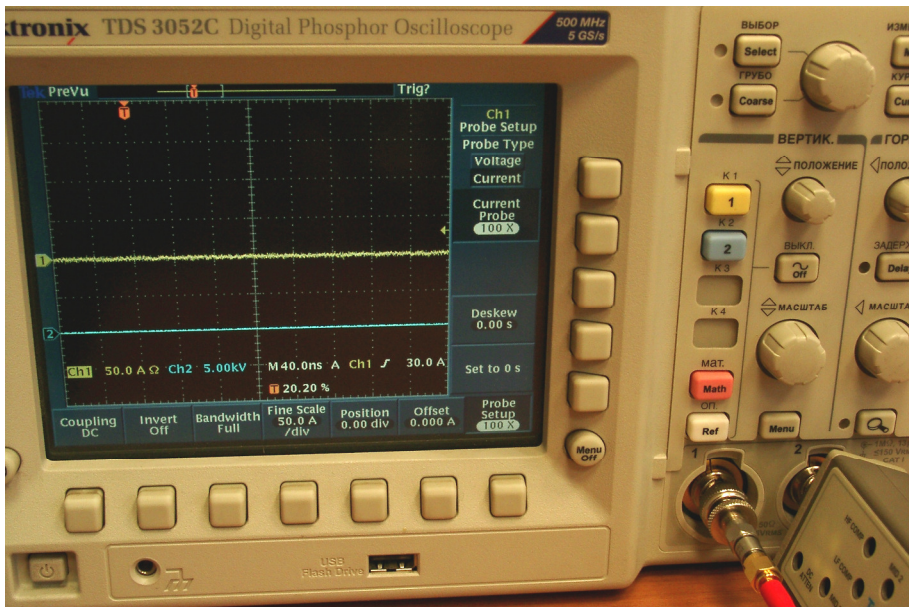

Fig.5. Setting of the oscilloscope CH1 for operation with the shunt.

- ➔ Do not connect the shunt to the oscilloscope input directly without 20dB attenuator. It may result in permanent damage of the oscilloscope input channel. The pulse voltage amplitude of the signal from the shunt is more than 20V, therefore, it should be divided in 10 times or more.

### Step 5.

Switch on the high voltage pulse generator and register pulse current waveform through the load.

The simple barrier discharge set up with CS-10/500 current measurement shunt is shown in Fig. 6.

The simultaneous pulse voltage and current measurement by Tektronix P6015A probe and CS-10/500 shunt is shown in Fig. 7. Please connect the oscilloscope ground clip contact just to the ground contact of the shunt. It should be noted that simultaneous voltage-current measurement may lead to higher interference and noisy registered signal.

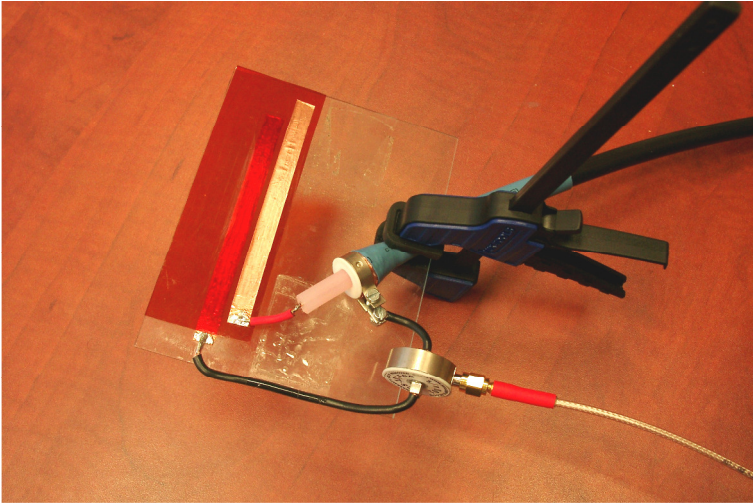

Fig. 6. CS-10/500 current measurement shunt serially connected with the load. One can see output HV coaxial cable fixed by the clip, simple barrier discharge load made of two copper foils separated by polyimide film and CS-10/500 shunt.

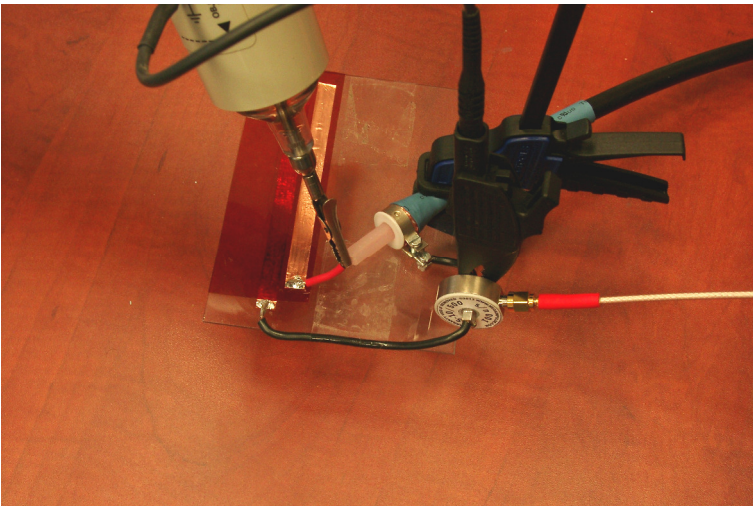

Fig. 7. Connection of P6015A probe and CS-10/500 shunt for simultaneous pulse voltage and pulse current measurement.

## **WARRANTY**

Please see your sales agreement to determine the warranty period and warranty condition. Warranty terminates if the shunt label is removed as well as in case of mechanical damage of the shunt or improper operation.